

CONDENSATE REMOVAL PUMP

EC-1 Series

APPLICATIONS

EC-1 is designed for use in removing condensate from wall mount, ductless mini-split air conditioners up to 10 kW. It can also be used to remove condensate from fan coils and suspended ceiling air conditioners. The pump can be installed above the air conditioner in a false ceiling, behind the wall mount air handler, or in plastic conduit or line-set channel. The reservoir, featuring a clear tank, connects to the condensate drain hose and must be positioned flat and horizontal while the pump can be oriented in any position within 1 meter.

FEATURES

The EC-1 Series is a new concept for mini pumps incorporating an improved noise reducing design and reliable solid-state switching technology. Easy to install brackets provide a quick and precise method to accurately position and secure both parts of the pump quickly. The two piece design allows the reservoir to be placed within the air handler while the pump-controller is located outside the air handler. The two components are connected via a convenient communications wire and suction tubing.

Pump - Controller

- Normally-closed relay rated at 8 A resistive - 250 V alarm
- 21 dB(A)*
- 6 mm pump discharge outlet
- Elastomeric mounting grommets on pump housing bracket
- Elastomeric passive vibration isolator used to dampen pump vibration
- Separate wall bracket for pump and reservoir included
- Thermal protection: 80 °C
- 1.5 m power cable
- 1 m communications cable (pump to reservoir)
- Ambient temperature range: 0 °C - 60 °C
- Maximum water temperature: 60 °C

Reservoir

- Clear reservoir for instant visual inspection of water level, float, and filter
- Hall effect on/off level sensors with high water safety sensor feature
- Extra-large filter screen for longer intervals between cleaning
- Multi-step drain hose adapter (14 mm, 16 mm, 18 mm, and 20 mm)
- Simple to open reservoir for easy maintenance



ENGINEERING DATA

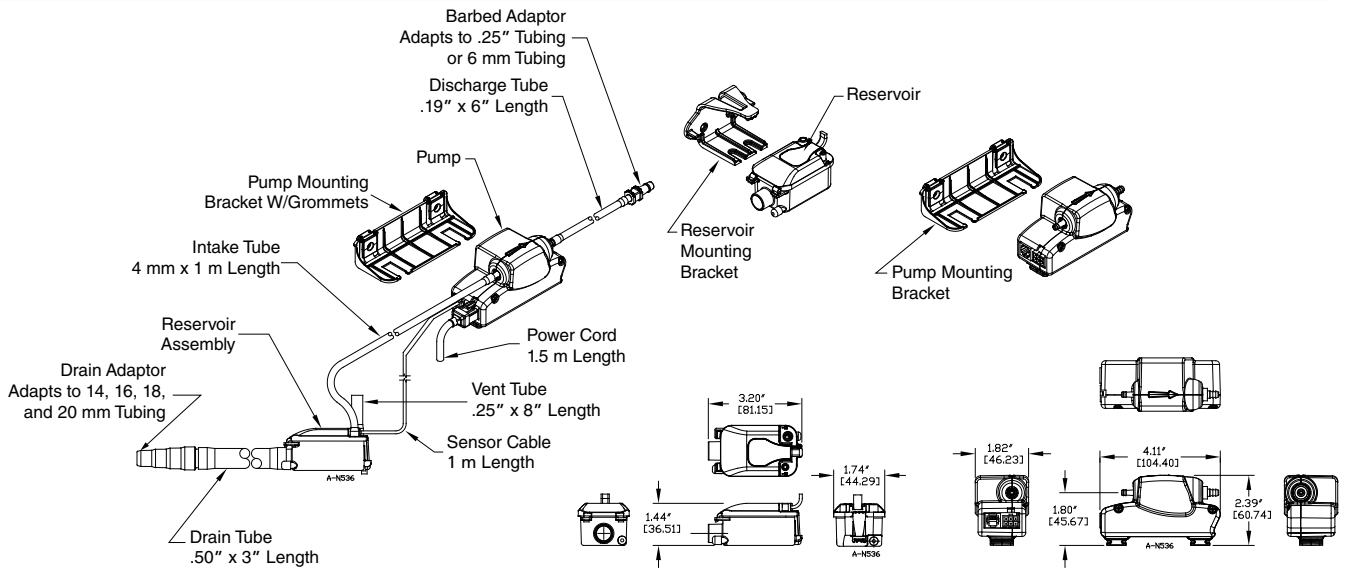

SPECIFICATIONS

Item No.	Model No.	Discharge Size	Volts	Hertz	Liters per Hour, at Height, 50 Hz				Shut Off	Suction Lift	Weight (kg)	Dimensions (H x L x W mm)
					0 m	1.5 m	3 m	6.1 m				
553502	EC-1	6 mm	230	50	10	6.8	5.7	4.5	10 m	1 m	0.80	104 x 46 x 58
Reservoir												84 x 46 x 38

PERFORMANCE DATA

230 V, 50 HZ

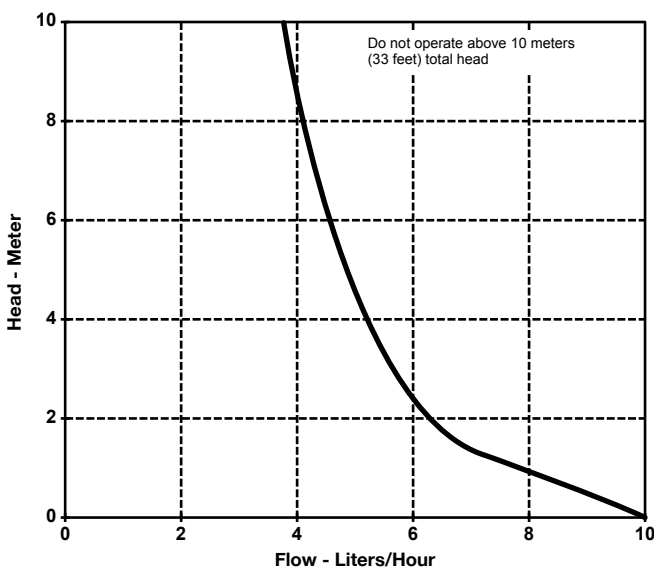

*Tested under conditions assumed consistent with competitors' published sound ratings.